

SafeZone Series

Safety Products for Temporary Traffic Control



Model SZ-412 Springless Stand



Safety

Bright orange, powder coated legs allow the SZ-412 sign stand to be seen from highways to city sidewalks.

Nut and Bolt Construction

Replacement parts kits are available. Simple nut and bolt construction allow for fast repairs. They can be replaced easily in the field, using simple hand tools!

Visibility

The SZ-412 sign stand holds roll-up signs 12" above the surface. This stand is MUTCD compliance and MASH approved.

Ease of Use

Our patented Auto-Latch on SZ-412 has a single attachment point to hold and display the roll-up signs, making it quick, simple and easy to use!

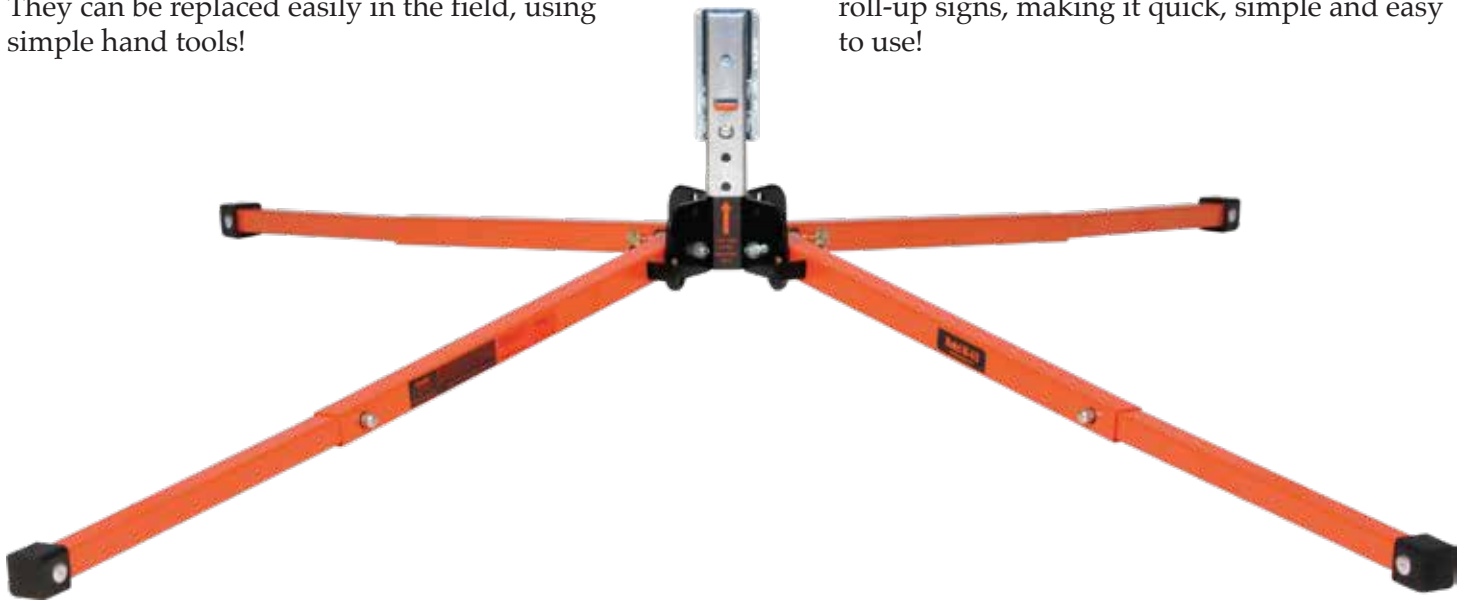

Crash Test Breakaway Base

The SZ-412 Series breakaway base is the first of its kind. It has been designed, when impacted, to rotate 90 degrees to the ground causing no damage to the undercarriage of the impacting vehicle.

The SZ-412 meets MASH crashworthiness guidelines.

BONE SAFETY SIGNS • 6450 Industrial Way • Alpharetta GA, 30004
Toll Free: (800) 873-2399 • Phone: (770) 333-1635 • Fax: (770) 333-1639
E-mail: sales@bonesafety.com • Web: bonesafety.com

JAN 2025

SafeZone Series

Safety Products for Temporary Traffic Control



FEATURES



Compact & Lightweight

Measuring 6" x 6.5" x 24" when folded for storage, the SZ-412 sign stand requires a minimum amount of space used on your vehicle and, at just 17.75 lbs, it's easy to carry for setup.

Pull Pin/Step Release Levers

The dual pull pin/step release lever allows each leg to be deployed by either pulling the pin by hand or by stepping on the step release at the user's option. Pull-pins also have oversized heads to make them easier to use with gloved hands, particularly in cold or winter conditions.

Maximum Stability:

The design features include three adjustable leg position for precise leveling, ensuring optimal stability and visibility on both even and uneven terrain. For best wind resistance legs must be fully extended.



DIMENSIONS

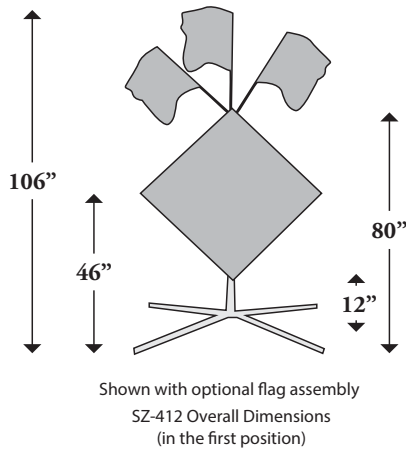

Folding Dimensions:	
Height:	24"
Weight:	16.25 lbs.
	17.75 lbs. w/ Auto-Latch BRKT.
Area:	6" x 6.5" x 24"
Storage:	0.52 Cubic Ft.

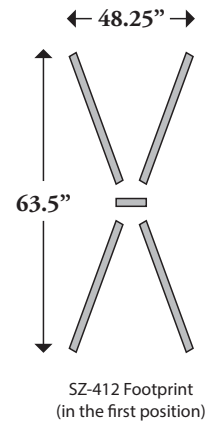

ACCESSORIES

Universal Bracket

Our heavy-duty Universal Bracket allows the use of our SafeZone Series Sign Stands with other manufacturers' Roll-Up signs, including those with "sewn" corner pockets.

Part # SZ-412-UB or SZ-412-UBT



UB



UBT

SafeZone Series

Safety Products for Temporary Traffic Control



Model SZ-412

Specification

Features:

- Lightweight design / 17.75 lbs.
- Compact for ease in storage / 0.52 cubic ft. when stored
- Springless design
- Over-sized pull pins and step release for quick release of legs
- 3 Separate height adjustments for uneven terrain
- Bright orange legs for extra visibility on curbs & sidewalks
- Powder-coated and zinc plated for maximum corrosion resistance

Specification

The sign stand shall be designed to attach roll-up signs up to 48" x 48" in size with a minimum bottom height of 12". This product has been independently tested and certified for use as a temporary traffic control device as specified under MASH guidelines. All sign stands shall be manufactured from steel component parts which have been powder-coated and clear zinc-plated to minimize corrosion and have a minimum wall thickness of 0.059 inches. The sign shall be designed using basic nut & bolt construction, so that all component parts may be readily replaced if worn or damaged.

The sign stand shall allow wind spillage on the sign face from any direction and be capable of withstanding wind gusts up to 70 m.p.h. without requiring additional ballast or tie downs. The sign stand shall not require additional hardware to attach the roll-up sign to the stand. An auto-latch bracket assembly securely fastened by means of snap quick release, shall provide a positive guide and down stop position as well as a secure single-point attachment between the two-piece polycarbonate corner pocket and the stand. The sign stand auto-latch bracket shall have a quick release lever to release the roll-up sign from the stand's single-point attachment by means of a single upward lifting motion of the auto-latch bracket release lever, in concert with a lifting and sliding motion of the roll-up sign. The lifting motion of the roll-up sign slides the sign's single attachment point polycarbonate pocket assembly out of the stand's auto-latch bracket assembly. The mast of the sign stand shall incorporate a nickel-plated quick release snap button to attach the auto-latch bracket, as well as optional accessories to the sign stand.

The legs of the sign stand shall be independently adjustable as well as multi-positional to accommodate uneven terrain or placement on curbs. All four legs shall have a telescopic inner leg for maximum footprint in heavy winds. Legs must have three independent adjustments for bottom height with a minimum 12" bottom height in first position. Legs shall have both a pull-pin and step release mechanism for releasing legs. Pull-pins shall have oversized heads to allow for gloved hands in winter environments. The sign stand shall measure 6"x 6.5"x 24" when folded for storage and have a total weight of 17.75 lbs.

SafeZone Series

Safety Products for Temporary Traffic Control



EXPLODED VIEW SZ-412

- 1 Stand Base Assembly
- 2 Mast Assembly
- 3 Auto-Latch
- 4 Complete Outer Assembly
- 5 Complete Inner Assembly

